



STI 11

Edition 2/October 2000

Interface technical specifications
for France Telecom's network

Directive 1999/5/EC

Characteristics of Metropolitan Transfix service access interfaces

Summary: This document gives a brief description of the Metropolitan Transfix service, and describes the technical characteristics of the interfaces used for accessing this service.

Warning :

"Only the French text is authentic; therefore France Telecom accepts no responsibility or liability whatsoever with regard to any information or data referred to in this document".

France Telecom
6, Place d'Alleray
75505 Paris Cedex 15
France

<http://www.francetelecom.com>

Notice

Information enclosed in this document is at terminal equipment manufacturers' disposal, pursuant to Directive 1999/5/EC of the European Parliament and of the Council of 9 March 1999 on radio equipment and telecommunications terminal equipment and the mutual recognition of their conformity.

According to Directive 1999/5/EC and specially Article 4.2, France Telecom reserves the right to modify or complement the information contained in this document in order to update the interface technical specifications and to allow the creation of telecommunication terminal equipments capable of using the services provided by the corresponding interfaces.

France Telecom can be held responsible neither for non-operation or poor operation of a terminal equipment, if the equipment complies with this specification, nor for any damage resulting from the use or misuse of the information contained in this document, towards whoever it be.

Provision of these technical specifications results in no transfer of rights, no granting of license on any intellectual property right, belonging to France Telecom.

France Telecom holds exclusive rights on France Telecom brands mentioned in this document.

France Telecom further points out users' attention on the following points:

1. timer values are indicative and can be subject to modification,
2. due to various technical constraints, some services or service options may not be available on some interfaces,
3. the fact that a service not yet commercially open is described in this document can in no case be considered as a binding commitment on France Telecom part to actually open this service.

Table of contents

1. OVERVIEW OF THE SERVICE	1
1.1 DEFINITION OF THE SERVICE	1
1.2 SYNCHRONISATION	2
2. METROPOLITAN TRANSFIX ON MULTICHANNEL INTERFACE	2
2.1 DEFINITION OF THE SERVICE	2
2.2 CONNECTION INTERFACE.....	3
2.2.1 Test loops.....	3
2.2.2 DCE reaction to transmission problems.....	3
2.2.3 DCE reaction to TS/TS loops	3
3. METROPOLITAN TRANSFIX ON DEDICATED X.24/V.11 INTERFACE	4
3.1 DEFINITION OF THE SERVICE	4
3.2 CONNECTION INTERFACE.....	5
3.3 OPERATION	5
3.3.1 Signalling transport.....	5
3.3.2 Test loops.....	5
3.3.3 DCE reaction to transmission problems.....	5
4. METROPOLITAN TRANSFIX ON DEDICATED V.36 INTERFACE	6
4.1 DEFINITION OF THE SERVICE	6
4.2 CONNECTION INTERFACE.....	6
4.3 CONNECTOR.....	7
4.4 OPERATION	7
4.4.1 Signalling transport.....	7
4.4.2 Test loops.....	7
4.4.3 DCE reaction to transmission problems.....	7
5. METROPOLITAN TRANSFIX ON DEDICATED V.35 INTERFACE	8
5.1 DEFINITION OF THE SERVICE	8
5.2 CONNECTION INTERFACE.....	8
5.3 CONNECTOR.....	9
5.4 OPERATION	9
5.4.1 Signalling transport.....	9
5.4.2 Test loops.....	9
5.4.3 DCE reaction to transmission problems.....	9
6. METROPOLITAN TRANSFIX ON DEDICATED G.703/G.704 INTERFACE	10
6.1 DEFINITION OF THE SERVICE	10
6.2 CONNECTION INTERFACE.....	10
6.3 OPERATION	11
6.3.1 Test loops.....	11
6.3.2 DCE reaction to transmission problems.....	11
6.3.3 DCE reaction to TS/TS loops	11
7. HISTORY.....	11

1. OVERVIEW OF THE SERVICE

1.1 DEFINITION OF THE SERVICE

France Telecom provides, between a customer's central site and various customer or third-party remote sites, a Metropolitan Transfix point-to-point digital leased link network with the following properties:

- ◆ Rates offered: 64, 128, 256, 512, 1024 and 1920 kbit/s.
- ◆ Access to the service is via a multichannel G.703/G.704 interface that groups a number of 64 kbit/s telephone links on the same site, or via a dedicated interface specific to each link.

Summary of rates offered according to interface type:

Interface	Rates available	Characteristics			Standardised name
		Functional	Electrical	Mechanical	
Multichannel G.703/G.704 interface	Composite telephone 64 kbit/s: 30x64 kbit/s	G.704	G.703	Sub-D 9-pin	Multichannel G.703/G.704
Dedicated G.703/G.704 interface	64, 128, 256, 512, 1024 and 1920 kbit/s	G.704	G.703	Sub-D 9-pin	G.703/G.704
Dedicated X.24/V.11 interface	64, 128, 256, 512, 1024 and 1920 kbit/s	X.24	V.11	ISO 4903 15-pin	X.24/V.11
Dedicated V.36 interface	64 kbit/s	V.24	V.11(V.10)	ISO 4902 37-pin	X.21 bis
Dedicated V.35 interface	64 kbit/s	V.24	V.11(V.10)	ISO 2593 34-pin	X.21 bis

For each type of interface, the range of the physical interface, the connection interface and the operation are described in the corresponding chapters.

Metropolitan Transfix leased link:

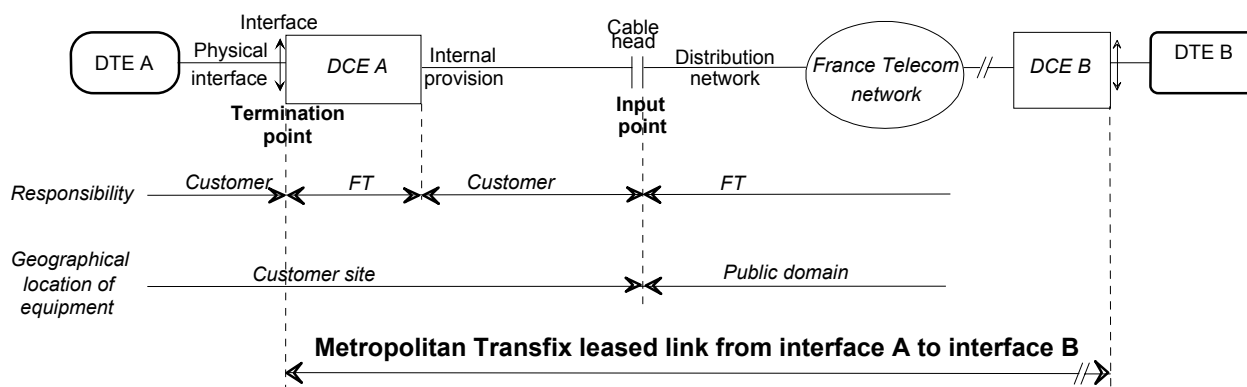

Data Terminal Equipment (DTE): The equipment that transmits or receives data (router, multiplexer, automatic branch exchange, computer equipment, etc.).

Data Circuit terminating Equipment (DCE): The equipment supplied, installed and maintained by France Telecom, to which the DTE is connected.

The connecting cable between the customer DTE and the service termination point is supplied by the customer.

1.2 SYNCHRONISATION

The leased link network is synchronised by France Telecom via the interface provided to the customer.

The clock frequencies transmitted by the DTE must be phase-locked to this interface's clock, as it is synchronised with France Telecom's reference timing.

If the clock frequencies are not aligned in the two transmission directions, they are adjusted by way of frame jumps or repeated frames.

2. METROPOLITAN TRANSFIX ON MULTICHANNEL INTERFACE

2.1 DEFINITION OF THE SERVICE

France Telecom provides, between a customer's central site and various customer remote sites, 64 kbit/s (unit rate) telephone leased links with the following properties:

- ◆ Access to the service on the central site is via a multichannel interface that groups a number of links on a single multichannel G.703/G.704 interface.
- ◆ Access to the service on remote sites is also via a multichannel G.703/G.704 interface.
- ◆ The maximum composite bit rate on the multichannel interface cannot exceed 1920 kbit/s, i.e. 30x64 kbit/s.
- ◆ Link demultiplexing is carried out by the customer or third party DTE.
- ◆ The signalling associated with each 64 kbit/s telephone link is transmitted end-to-end, if it complies with § 5.1.3.2 of ITU-T Recommendation G.704 (channel associated signalling on bit a of TS 16). In accordance with Recommendation G.704, the value of bit b of each signalling nibble associated with the channels used is always 1, the value of bit c is always 0, and the value of bit d is always 1. State changes to bit a of the G.704 frame transmitted by the DTE must be greater than the minimum values, which are 40 ms for fast state changes and 8 ms for isolated state changes.

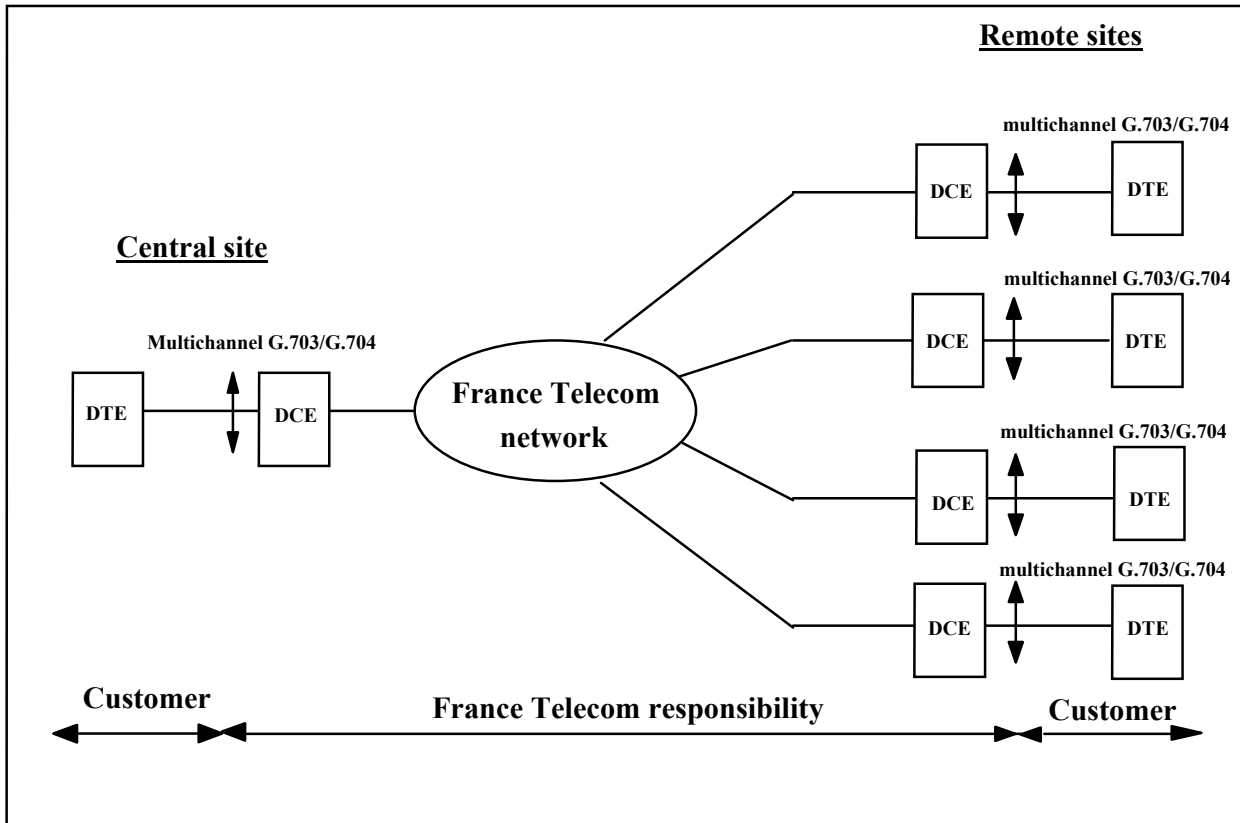

Note 1: Time Slot (TS 0) of the G.704 frame delivered by the customer DTE must comply with section 2.3.2 of Recommendation G.704, but it is not transmitted in the network; the DCE analyses and stops these bits.

Note 2: The integrity of the bit sequence transmitted is respected.

2.2 CONNECTION INTERFACE

The connection interface is a shielded 4-wire symmetrical pair interface. The electrical characteristics comply with chapter 6 of Recommendation G.703.

2.2.1 TEST LOOPS

The customer cannot access the test loops.

2.2.2 DCE REACTION TO TRANSMISSION PROBLEMS

If there is a problem with the transmission channel or France Telecom enables a loop 2 on the access interface, the data transmitted to the local DTE is set to 1.

2.2.3 DCE REACTION TO TS/TS LOOPS

When France Telecom enables a TS/TS loop on the G.703/G.704 interface, this provokes:

- ◆ the loopback of data transmitted to the local DTE,
- ◆ the loopback of data transmitted to the remote DTE.

3. METROPOLITAN TRANSFIX ON DEDICATED X.24/V.11 INTERFACE

3.1 DEFINITION OF THE SERVICE

France Telecom provides, between a central site and various remote sites, a network of leased links with a rate of 64, 128, 256, 512, 1024 or 1920 kbit/s. Access to the service by each leased link is via a dedicated X.24/V.11 interface at each end of the link.

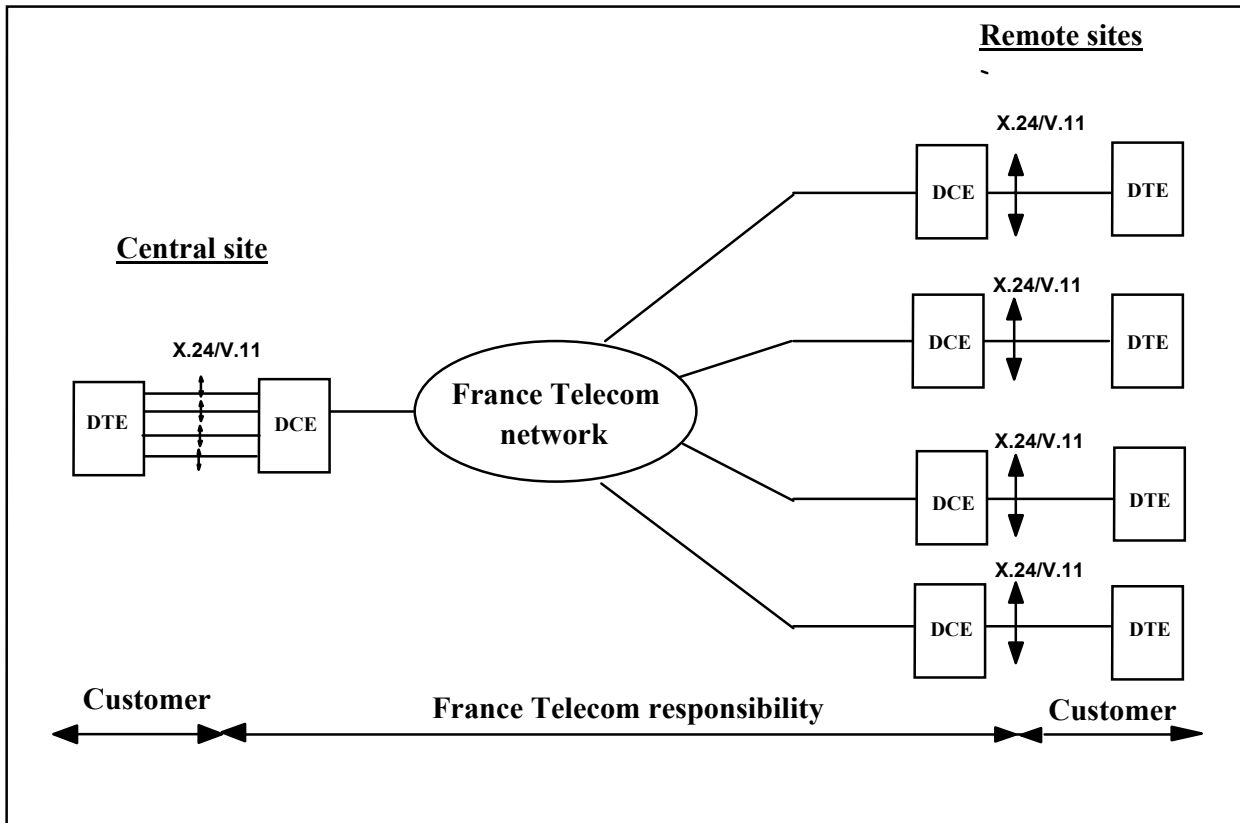

Note: The service can be accessed by all the links on the central site via the multichannel G.703/G.704 interface. In this case, the signalling associated with each link is not transmitted end-to-end.

3.2 CONNECTION INTERFACE

The functional characteristics of the circuits comply with Recommendation X.24.

The electrical characteristics concern the T, R, S, X, C and I circuits, and comply with Recommendation V.11. Only the G, T, R and S circuits are managed.

The interface is available on a 15-pin female connector (illustrated below) that complies with the ISO 4903 standard. The connector is attached to a distribution panel at the back of the DCE.

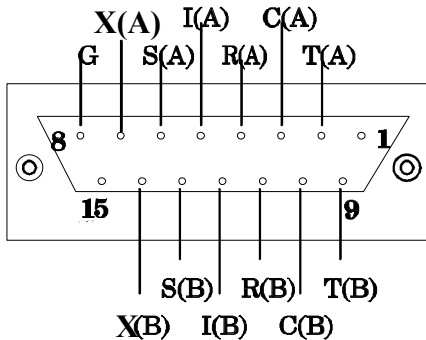

ISO 4903 connector – Contact side

3.3 OPERATION

3.3.1 SIGNALLING TRANSPORT

Signalling transport (state of the DCE I circuit) is not supported. At each end, whatever the state of the link, the DCE forces the I circuit open (logical state "1").

3.3.2 TEST LOOPS

The customer cannot access the test loops.

3.3.3 DCE REACTION TO TRANSMISSION PROBLEMS

If there is a problem with the transmission channel (reception direction) this may lead to the R circuit being set to 0 or 1, depending on the type of problem.

Note: The I circuit remains in logical state "1".

4. METROPOLITAN TRANSFIX ON DEDICATED V.36 INTERFACE

4.1 DEFINITION OF THE SERVICE

France Telecom provides, between a central site and various remote sites, a network of leased links with a rate of 64 kbit/s. Access to the service, for each end of the leased link, is via a dedicated V.24/V.11(V.10) interface (also called a V.36 interface).

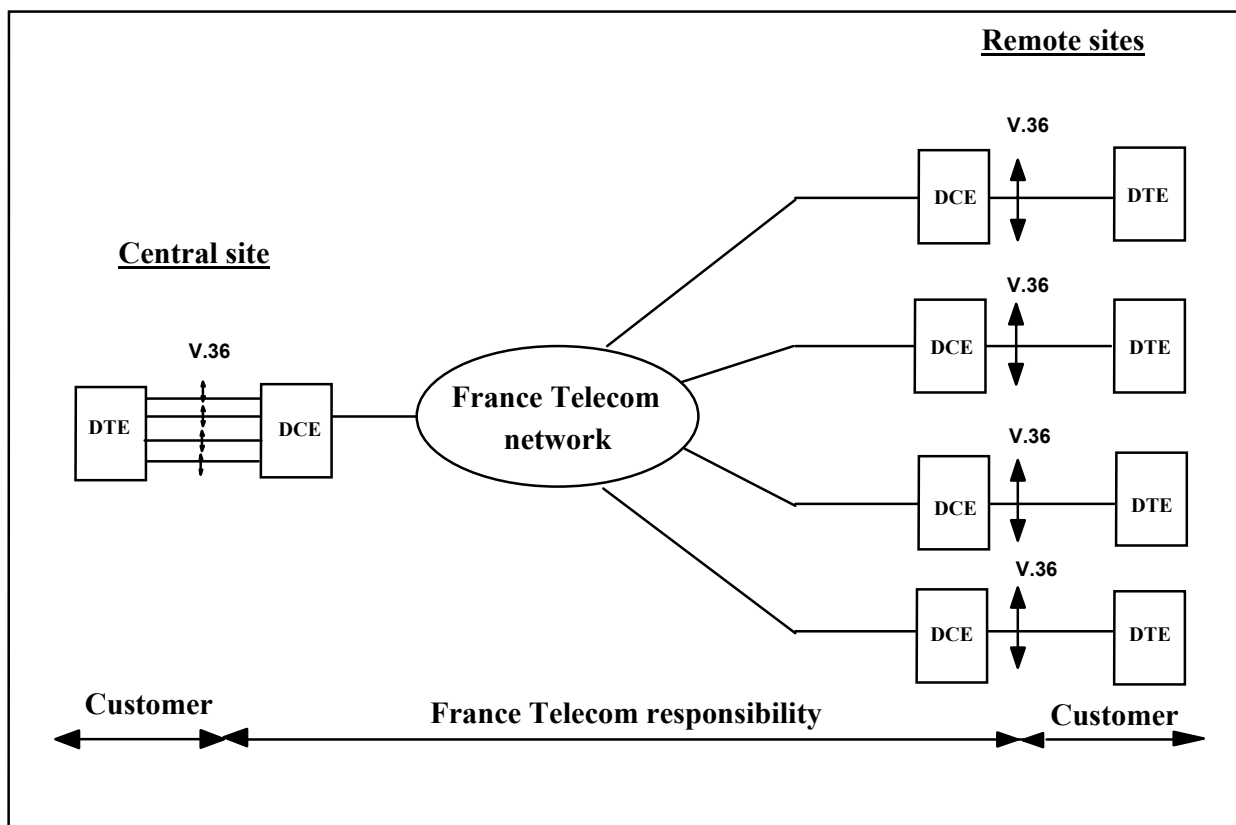

Note: The service can be accessed by all the links on the central site via the multichannel G.703/G.704 interface. In this case, the signalling associated with each link is not transmitted end-to-end.

4.2 CONNECTION INTERFACE

The functional characteristics of the circuits comply with Recommendation V.24.

The electrical characteristics of circuits 103, 104, 114 and 115 comply with Recommendation V.11.

The electrical characteristics of circuit 109 comply with Recommendation V.10. The receiver complies with Recommendation V.10 category 1 or V.11.

The electrical characteristics of circuits 105, 106, 107, 140 and 141 comply with Recommendation V.10. With a receiver, circuits 105, 106 and 107 comply with Recommendation V.10 category 1 or V.11, and circuits 140 and 141 comply with Recommendation V.10 category 2.

4.3 CONNECTOR

The interface is available on a 37-pin female connector (illustrated below) that complies with the ISO 4902 standard.

The connector is attached to a distribution panel at the back of the DCE.

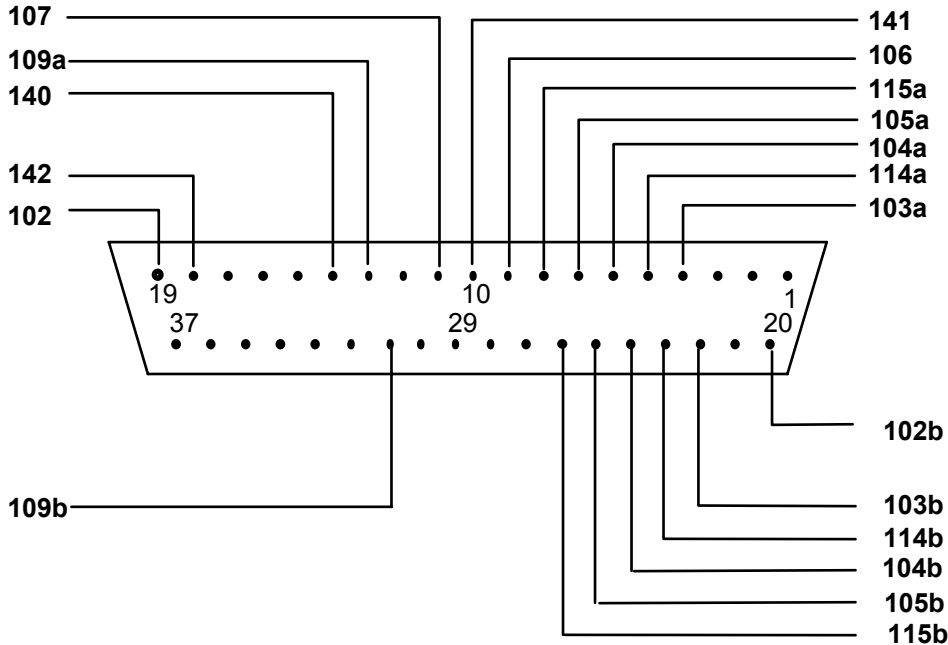

ISO 4902 connector - Contact side

4.4 OPERATION

4.4.1 SIGNALLING TRANSPORT

Signalling transport (state of DCE circuit 105) is not supported.

4.4.2 TEST LOOPS

The customer cannot access the test loops.

4.4.3 DCE REACTION TO TRANSMISSION PROBLEMS

If there is a problem with the transmission channel (reception direction), the data bits on circuit 104 are set to "0" or "1".

Note: Circuit 109 remains in logical state "1".

5. METROPOLITAN TRANSFIX ON DEDICATED V.35 INTERFACE

5.1 DEFINITION OF THE SERVICE

France Telecom provides, between a central site and various remote sites, a network of leased links with a rate of 64 kbit/s. Access to the service, for each end of the leased link, is via a dedicated V.24/V.11(V.10) interface (also called a V.35 interface).

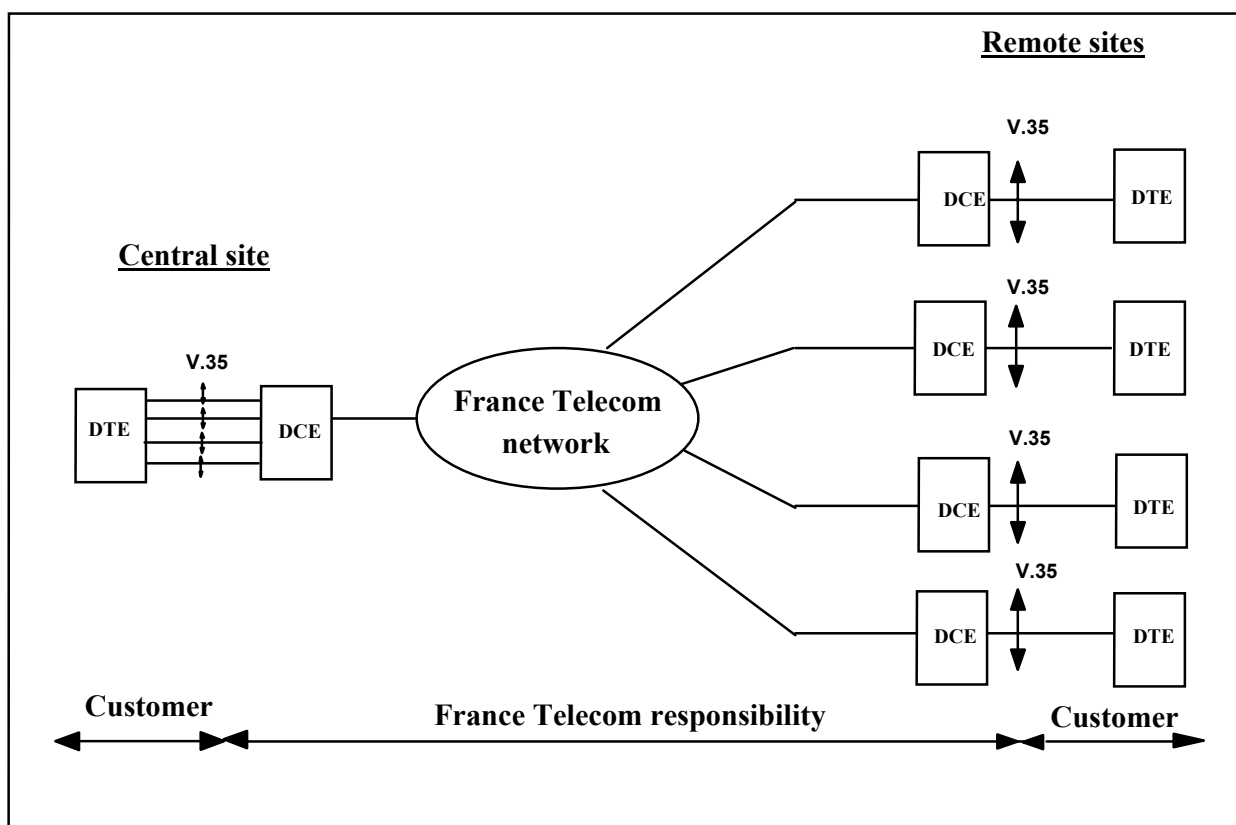

Note: The service can be accessed by all the links on the central site via the multichannel G.703/G.704 interface. In this case, the signalling associated with each link is not transmitted end-to-end.

5.2 CONNECTION INTERFACE

The functional characteristics of the circuits comply with Recommendation V.24.

The electrical characteristics of circuits 103, 104, 114 and 115 comply with Recommendation V.11.

The electrical characteristics of circuit 105, 106, 107 and 109 comply with Recommendation V.10. The receivers comply with Recommendation V.10 category 2. Circuits 140 and 142 are not present at the end of the adapter.

5.3 CONNECTOR

The interface is available on a 34-pin female connector (illustrated below) that complies with the ISO 2593 standard. **The pin diameter is 1.6 mm.**

The connector is attached to a distribution panel at the back of the DCE.

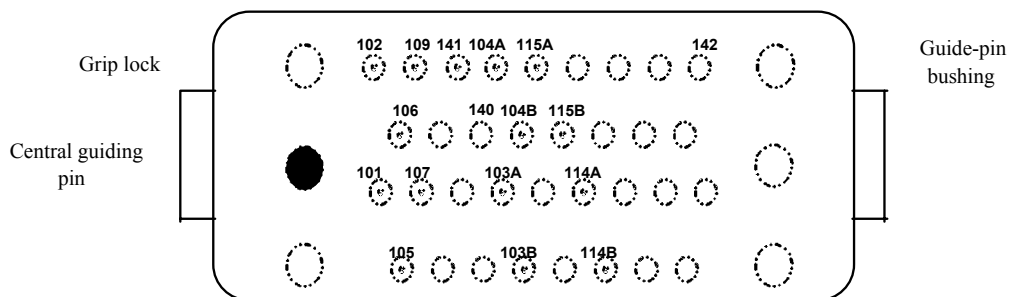

ISO 2593 connector - Contact side

5.4 OPERATION

5.4.1 SIGNALLING TRANSPORT

Signalling transport (state of DCE circuit 105) is not supported.

5.4.2 TEST LOOPS

The customer cannot access the test loops.

5.4.3 DCE REACTION TO TRANSMISSION PROBLEMS

If there is a problem with the transmission channel (reception direction), the data bits on circuit 104 are set to "0" or "1".

Note: Circuit 109 remains in logical state "1".

6. METROPOLITAN TRANSFIX ON DEDICATED G.703/G.704 INTERFACE

6.1 DEFINITION OF THE SERVICE

France Telecom provides, between a central site and various remote sites, a network of leased links with a rate of 64, 128, 256, 512, 1024 or 1920 kbit/s. Access to the service, by each leased link, is via a dedicated G.703/G.704 2048 kbit/s interface whose structure complies with Recommendation G.704 (§ 2.3 and § 5, excluding § 5.1.3).

Time Slot 0 (TS 0) of the G.704 frame delivered by the customer DTE must comply with section 2.3.2 of Recommendation G.704, but it is not transmitted in the network.

The integrity of the bit sequence transmitted is respected.

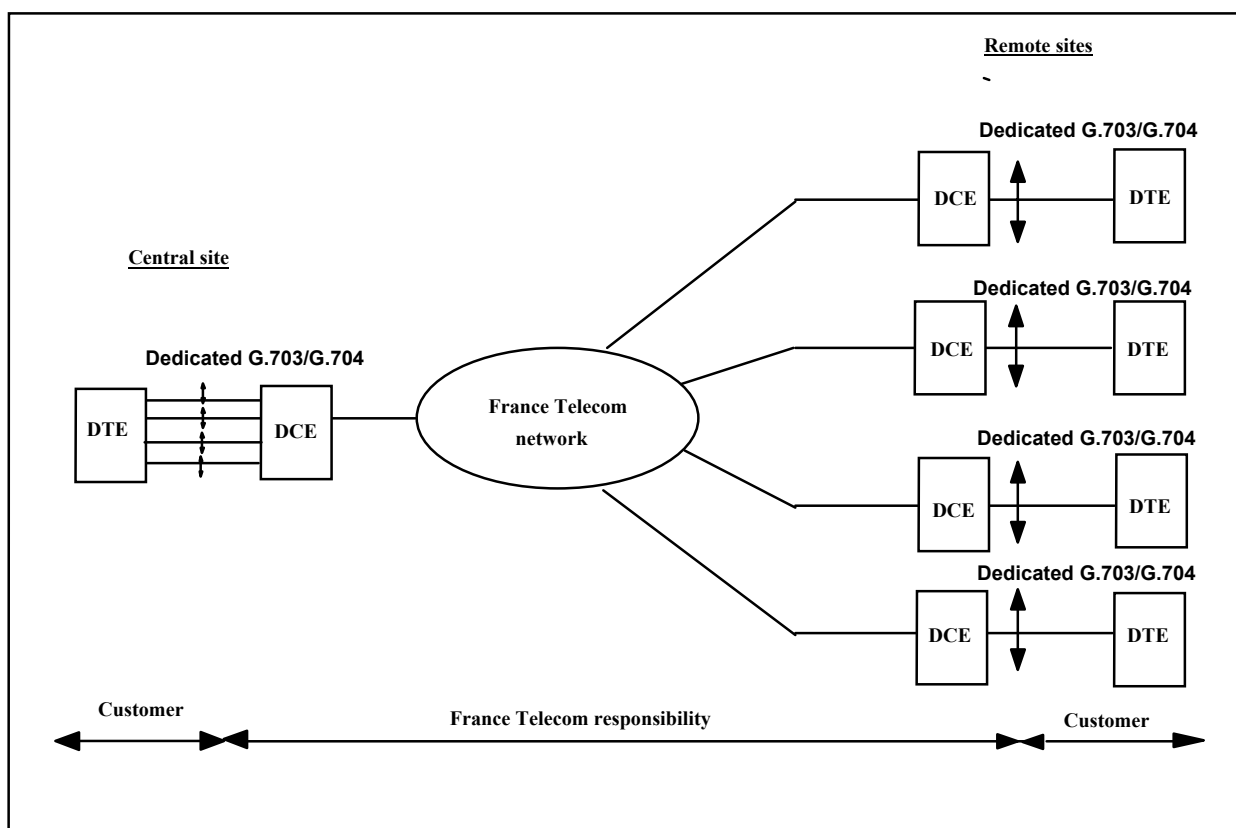

Note: The service can be accessed by all the links on the central site via the multichannel G.703/G.704 interface. In this case, the signalling associated with each link is not transmitted end-to-end.

6.2 CONNECTION INTERFACE

The connection interface is a shielded 4-wire symmetrical pair interface. The electrical characteristics comply with chapter 6 of Recommendation G.703.

6.3 OPERATION

6.3.1 TEST LOOPS

The customer cannot access the test loops.

6.3.2 DCE REACTION TO TRANSMISSION PROBLEMS

If there is a problem with the transmission channel or France Telecom enables a loop 2 on the access interface, the data transmitted to the local DTE is set to 1.

6.3.3 DCE REACTION TO TS/TS LOOPS

When France Telecom enables a TS/TS loop on the G.703/G.704 interface, this provokes:

- ◆ the loopback of data transmitted to the local DTE,
- ◆ the loopback of data transmitted to the remote DTE.

7. HISTORY

Edition	Date	Comments
1	March 2000	First version
2	October 2000	Title changed and minor modifications made